

Notes:
 All tubing is 1" x 1" x 1/8" wall A36 Steel.
 Cap all exposed tube ends, flush.
 Center leg end caps on legs.
 Center shelf on frame members.
 All welds 1/4" fillet.

ITEM NO.	PART NUMBER	DESCRIPTION	QTY.
1	right leg	38.5"	2
2	lower deck beam	63"	2
3	upper deck beam	42"	3
4	side beam	16"	4
5	column	20"	2
6	left leg	17.5"	2
7	leg end cap	See Detail	4
8	shelf	See Detail	1
9	pipe support bracket	See Detail	3

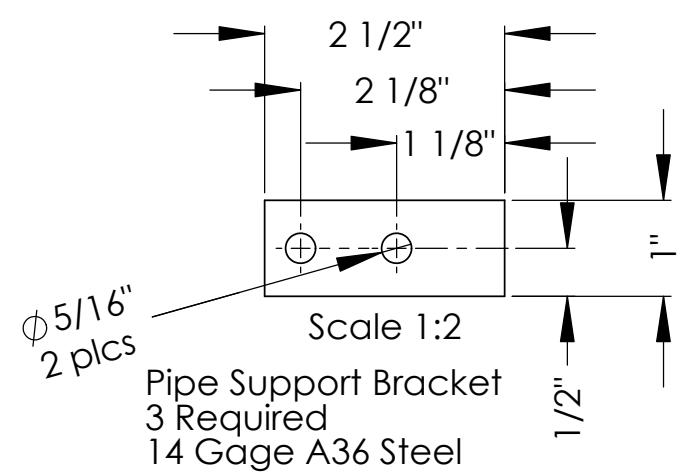
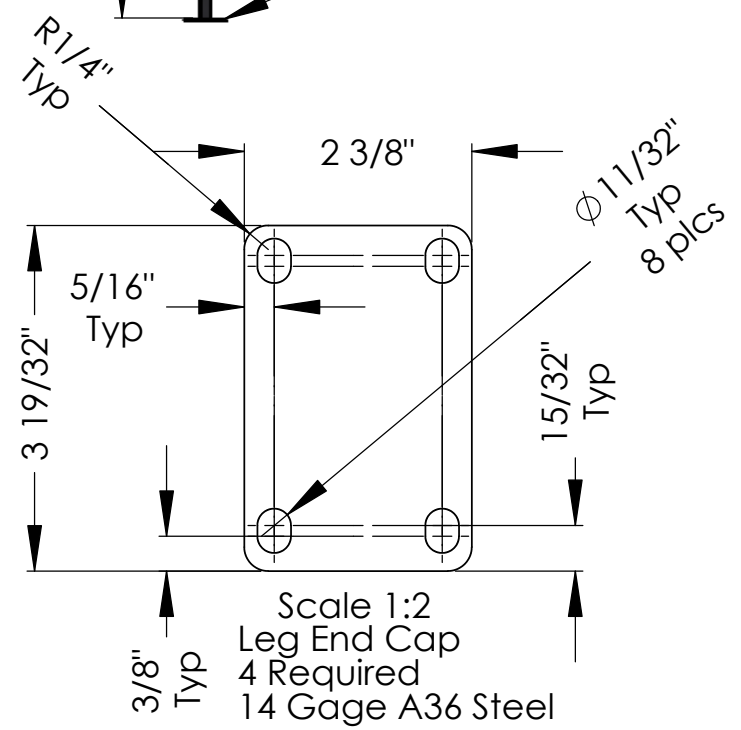

THE INFORMATION CONTAINED IN THIS DRAWING IS THE SOLE PROPERTY OF MALTY TASKING, LLC. ANY REPRODUCTION IN PART OR AS A WHOLE WITHOUT THE WRITTEN PERMISSION OF MALTY TASKING, LLC IS PROHIBITED.

PERSONAL USE GRANTED. FOR PERSONAL USE ONLY!

UNLESS OTHERWISE SPECIFIED:
 DIMENSIONS ARE IN INCHES
 TOLERANCES:
 Decimals X.XX ±0.050
 X.XXX ±0.010
 Hole Ø X.XX ±0.005
 X.XXX ±0.003
 ANGLES ±0.5°

DRAWING NUMBER: Frame Weldment/Parts		REV:
DESCRIPTION: Brewing System Frame Weldment		
PROJECT NAME: Malty Tasking Brewing System		
DRAWN BY: Steve Becker		SIZE
LOCATION: Your Brewery		B
VENDOR NAME: Local Blacksmith Shop		
VENDOR #:		
MASS:	MATERIAL:	
SCALE: 1:16	SHEET 1 OF 1	DATE: 8/2/2010

USE THIS DOCUMENT AS A GUIDE ONLY. MALTY TASKING, LLC IS NOT RESPONSIBLE FOR THE USE OF THIS INFORMATION.