

Burner Support Bracket  
 Material: 14 gage stainless steel.  
 3 required.  
 Fasten with stainless steel,  
 1/4" x 1/2" self tapping screws.

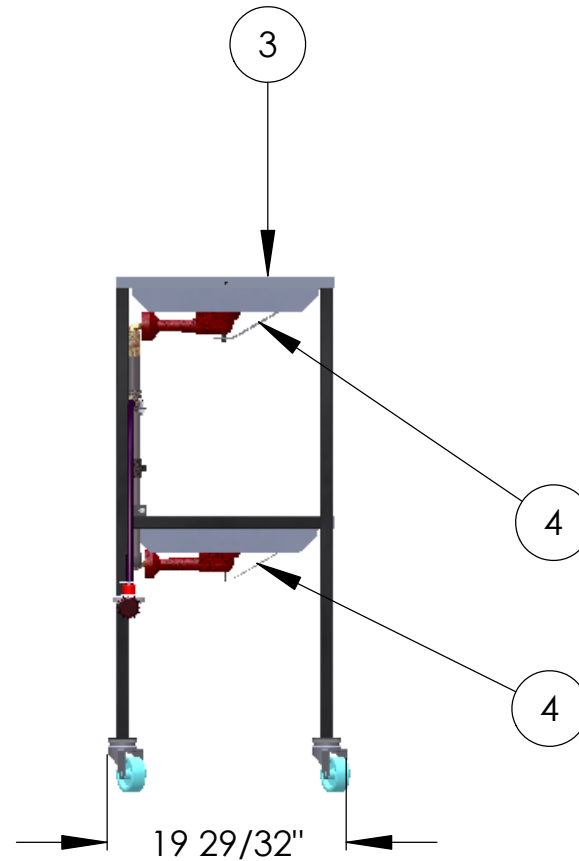
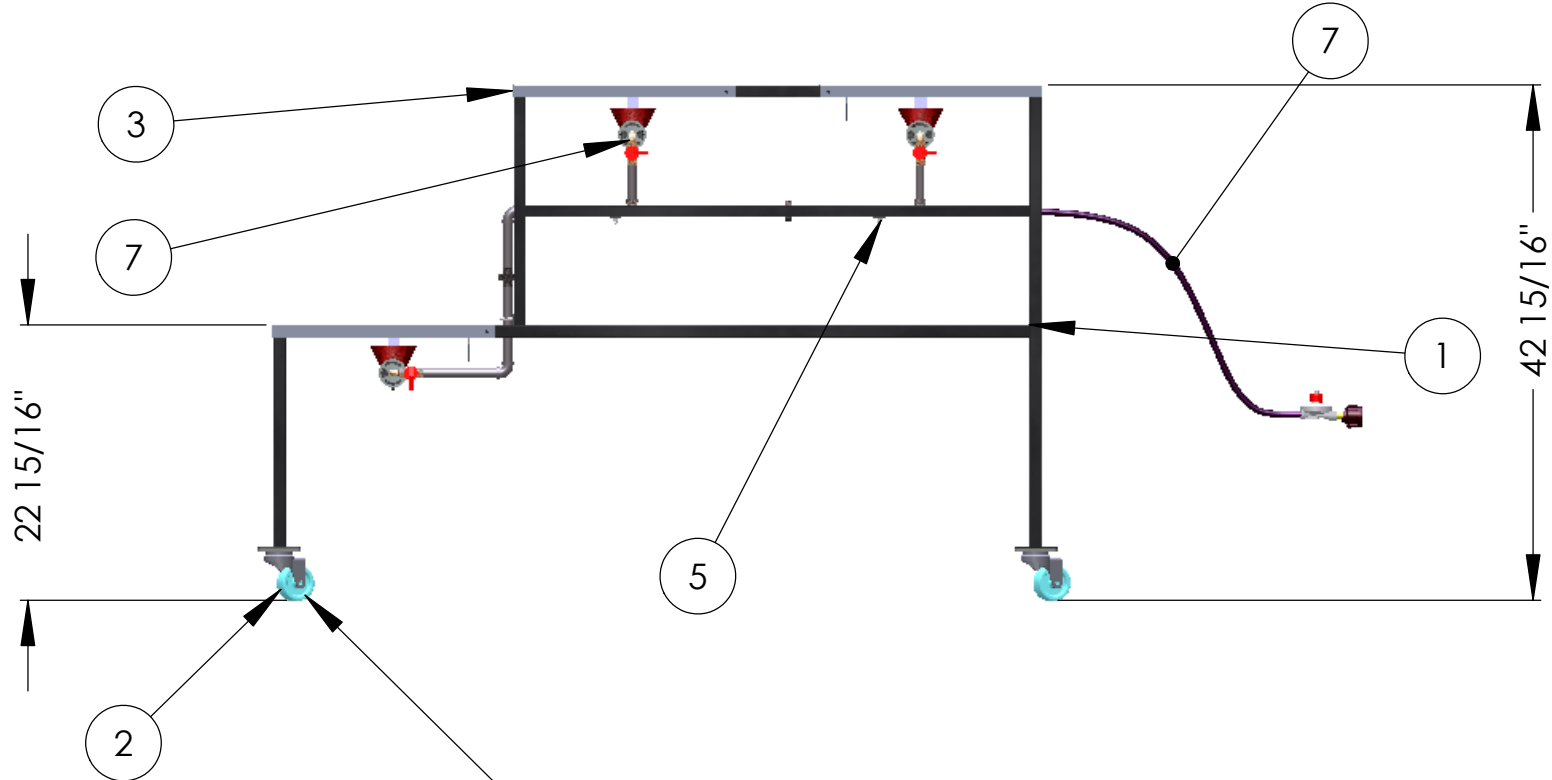
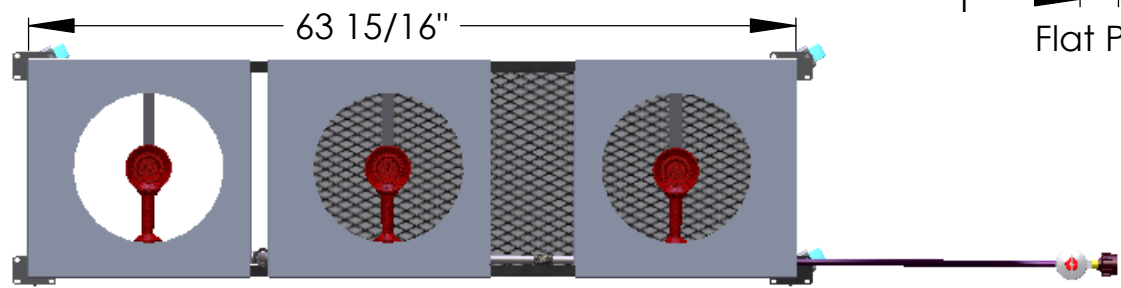
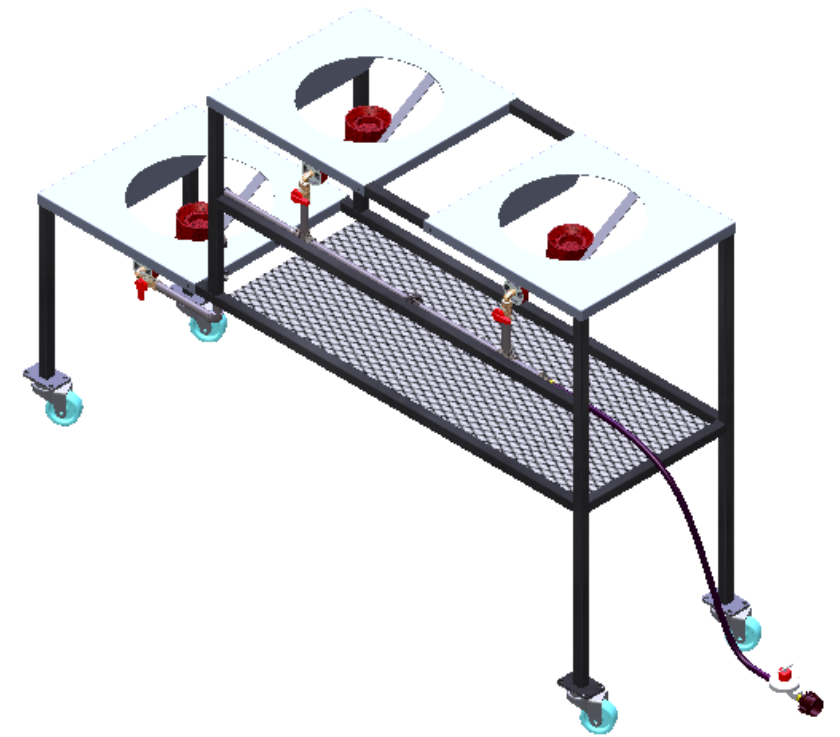
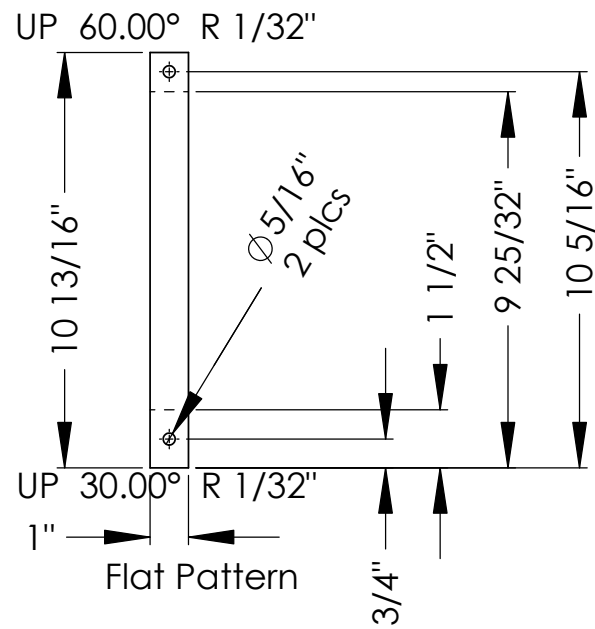
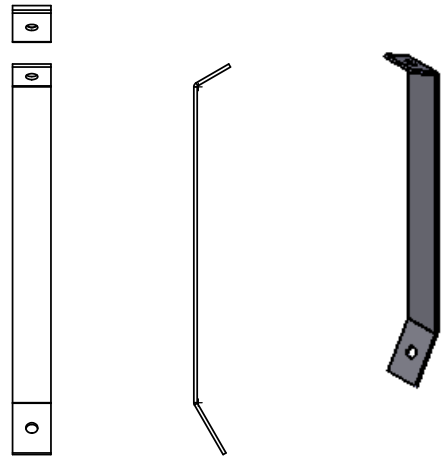

ITEM NO.	PART NUMBER	QTY.
1	Frame	1
2	3inch caster wheel	4
3	Malty Tasking Brewing System Burner Plate Assembly	3
4	Burner Support Bracket	3
5	Ubolt	3
6	Starter button	1
7	Malty Tasking Brewing System Gas Assembly	1

<http://www.mcmaster.com/#2358t26/=8lvnb7>

Notes:  
 Fasten the burner plates with stainless steel, 1/4"x1/2", self tapping screws.  
 Place some high temperature insulation between the burner plates and the frame to reduce heat transfer to the frame.

USE THIS DOCUMENT AS A GUIDE ONLY.  
 MALTY TASKING, LLC IS NOT RESPONSIBLE FOR THE USE OF THIS INFORMATION.



THE INFORMATION CONTAINED IN THIS DRAWING IS THE SOLE PROPERTY OF MALTY TASKING, LLC. ANY REPRODUCTION IN PART OR AS A WHOLE WITHOUT THE WRITTEN PERMISSION OF MALTY TASKING, LLC IS PROHIBITED.

PERSONAL USE GRANTED. FOR PERSONAL USE ONLY!

UNLESS OTHERWISE SPECIFIED:  
 DIMENSIONS ARE IN INCHES  
 TOLERANCES:  
 Decimals X.XX ±0.050  
 X.XXX ±0.010  
 Hole Ø X.XX ±0.005  
 X.XXX ±0.003  
 ANGLES ± 0.5°

DRAWING NUMBER: Frame Assembly REV:

DESCRIPTION: Brewing System Frame Assembly

PROJECT NAME: Malty Tasking Brewing System

DRAWN BY: Steve Becker

LOCATION: Your Brewery

VENDOR NAME: Local Blacksmith Shop

VENDOR #:

MASS: MATERIAL:

SCALE: 1:16 SHEET 1 OF 1 DATE: 8/28/2010

SIZE  
**B**